

CORROSAFE AS



MER ENN 60 ÅR MED ERFARING

VERDENS BESTE RUSTBESKYTTELSE



Hvorfor rustbeskytte din bil?

*Det norske klima er preget av mye
nedbør.
Fukt er hovedårsaken til rustdannelse.*

Biler er generelt ikke produsert for det harde og korrosive Norske været.

Vi salter mot is om vinteren
– som øker faren for korrosjon.

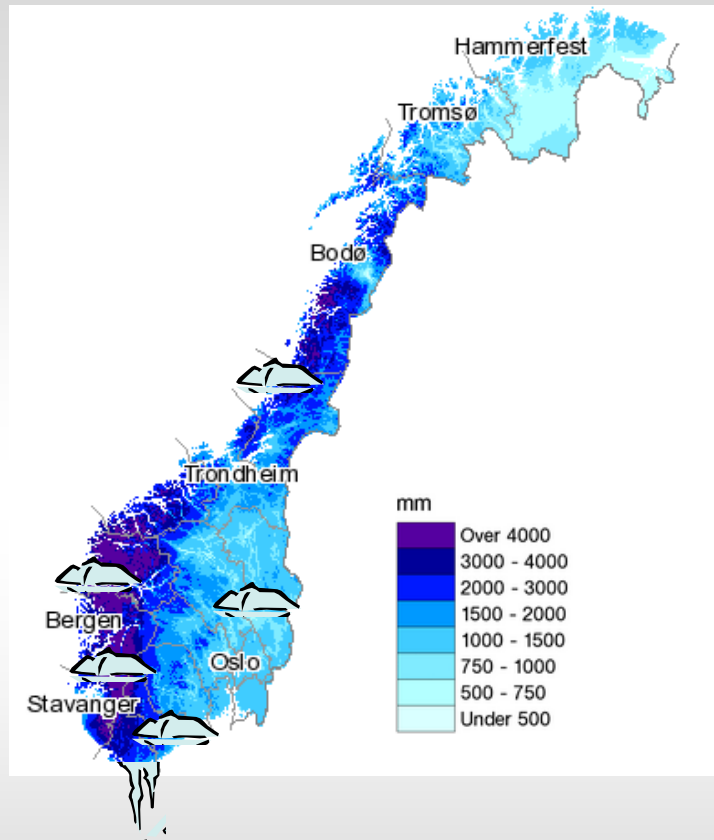

Beiser du huset ditt for å beskytte mot vær og vind?

Bilens vognbunn fortjener også vedlikehold.

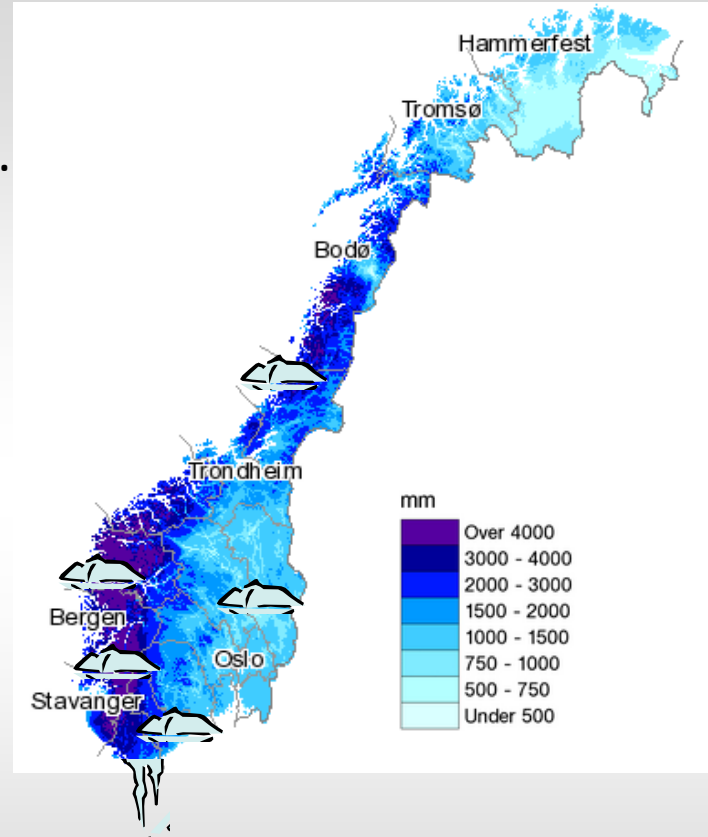



VERDENS BESTE RUSTBESKYTTELSE



Salt er energi for rustangrepet

VERDENS BESTE RUSTBESKYTTELSE





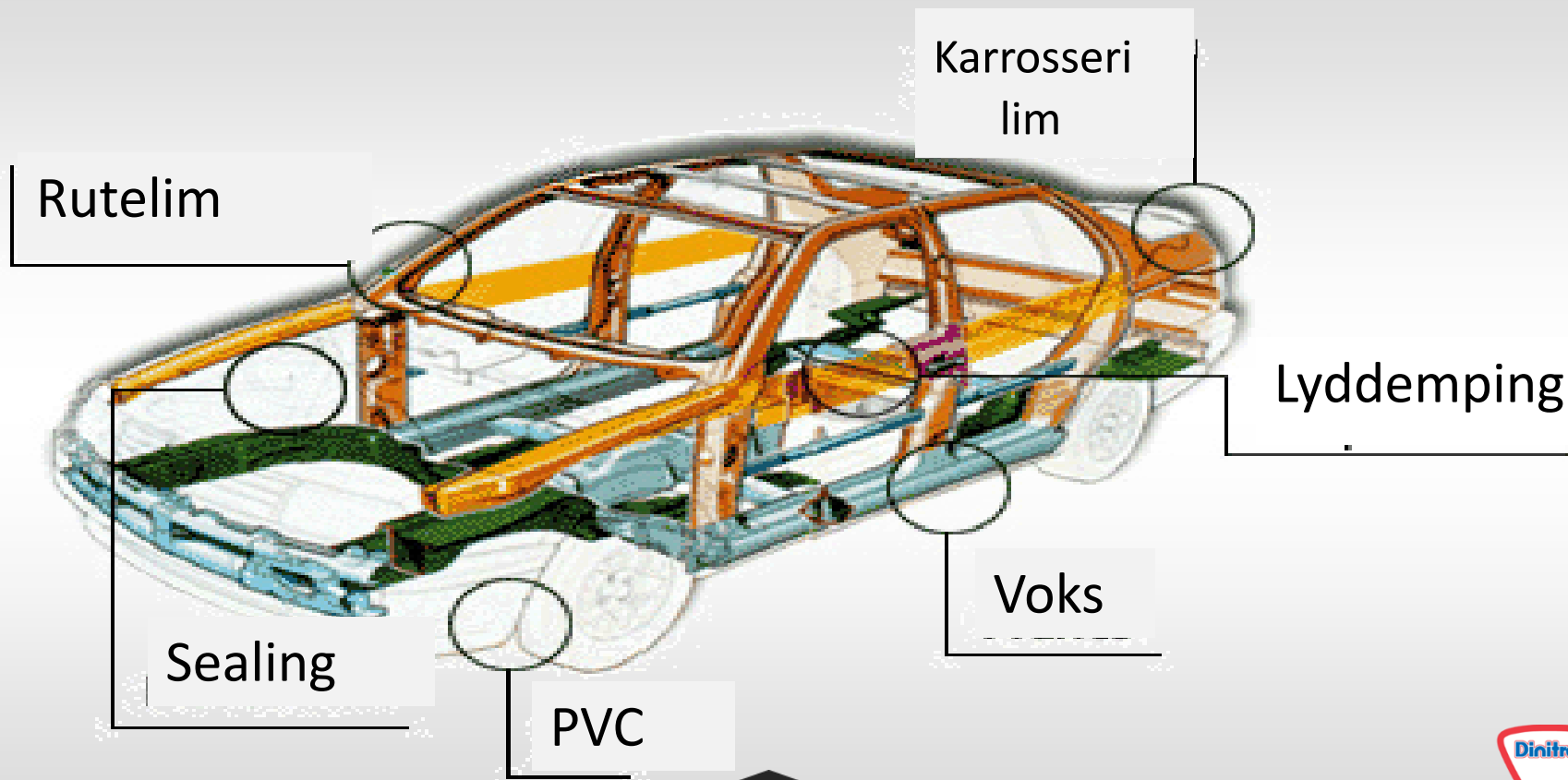

VERDENS BESTE RUSTBESKYTTELSE





Sealing



Rustbeskyttelse



Montering / Liming av ruter



VERDENS BESTE RUSTBESKYTTELSE



Behandlingsmengde

Fabrikk behandling

Dinitrol

Full TKD Behandling 7-8 Liter
Vognbunn Behandling 5-6 Liter

Under 1
liter

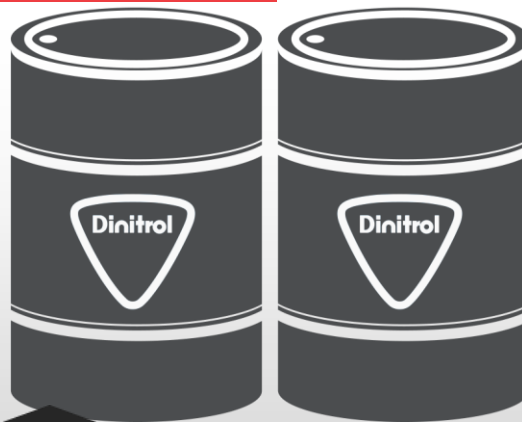

VERDENS BESTE RUSTBESKYTTELSE



Hvordan utføres rustbeskyttelse?



Demontering



Vask / avfetting



Tøking



Behandling



Klargjøring

VERDENS BESTE RUSTBESKYTTELSE





Demontering

VERDENS BESTE RUSTBESKYTTELSE





VERDENS BESTE RUSTBESKYTTELSE



Demontering 2009 <

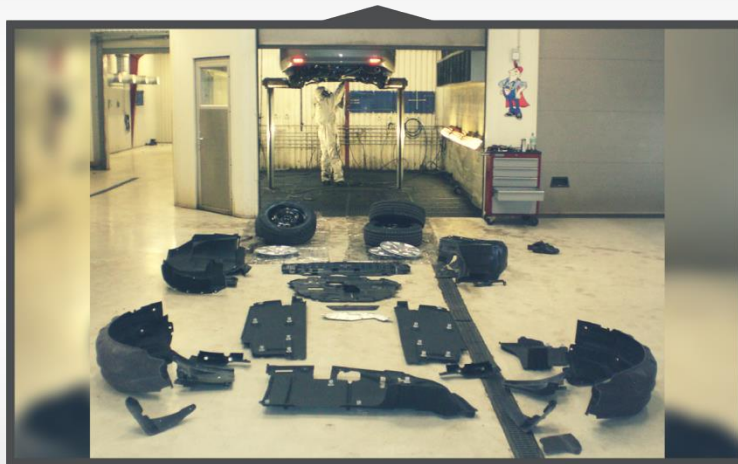

VERDENS BESTE RUSTBESKYTTELSE



*Hvorfor
"demontere"*

VERDENS BESTE RUSTBESKYTTELSE





Vask, avfetting og tørk

VERDENS BESTE RUSTBESKYTTELSE





VERDENS BESTE RUSTBESKYTTELSE



Opp til tre fjerdedeler av tiden

*brukes på forberedelse og
klargjøring.*



Behandling

VERDENS BESTE RUSTBESKYTTELSE



Vognbunns Behandling

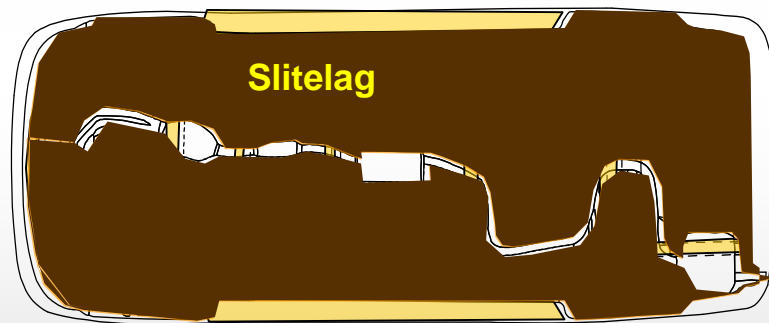
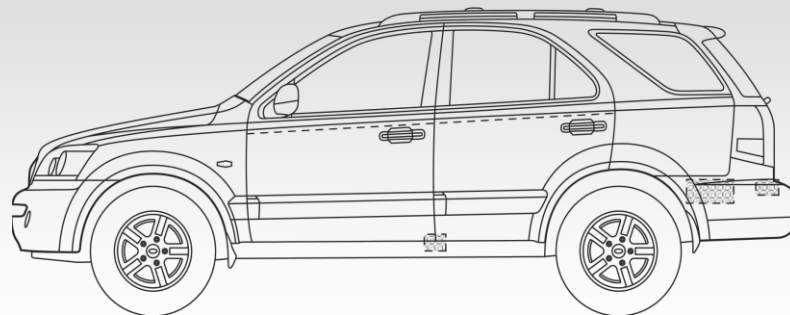

VERDENS BESTE RUSTBESKYTTELSE



Full TKD behandling.
Tillegg dører, bakluke og panser

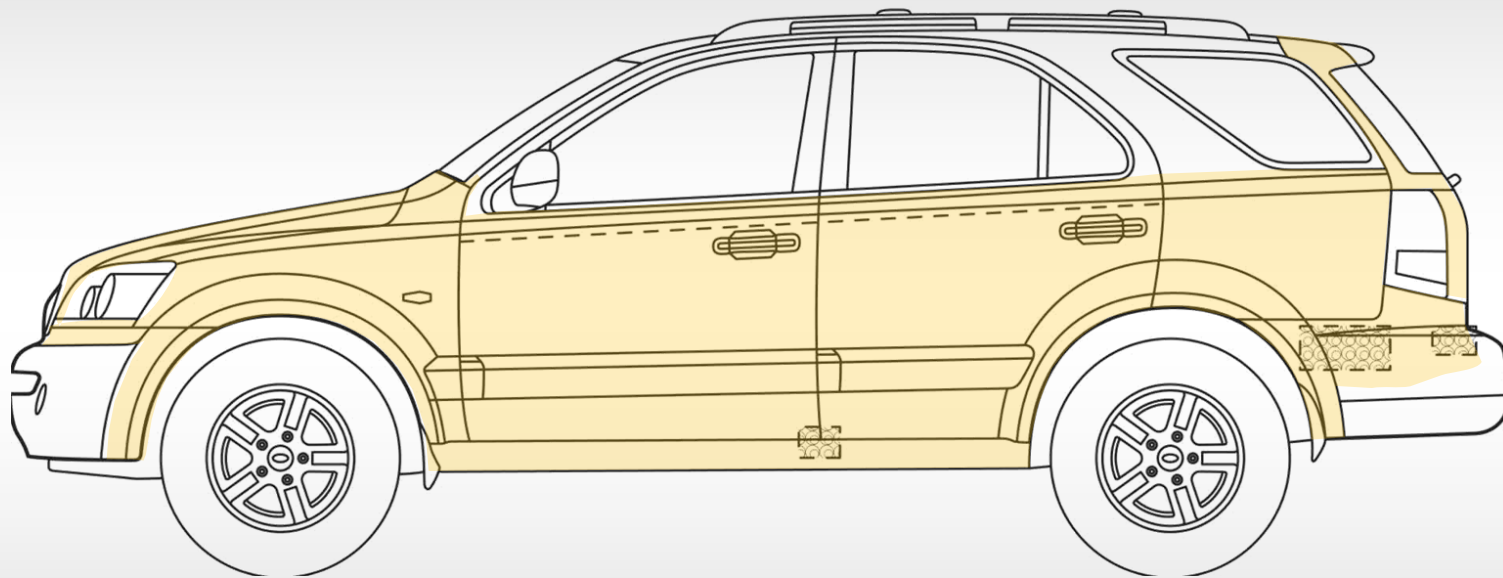

VERDENS BESTE RUSTBESKYTTELSE





Montering og klargjøring

VERDENS BESTE RUSTBESKYTTELSE





VERDENS BESTE RUSTBESKYTTELSE



Løsemiddel innhold produkter.

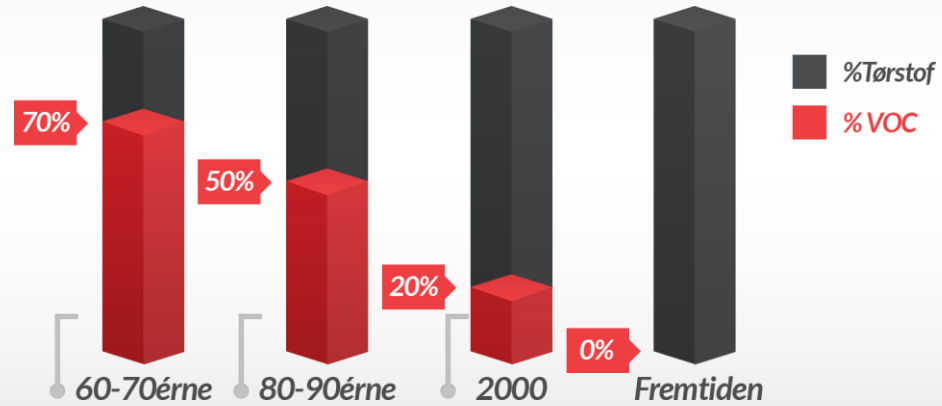

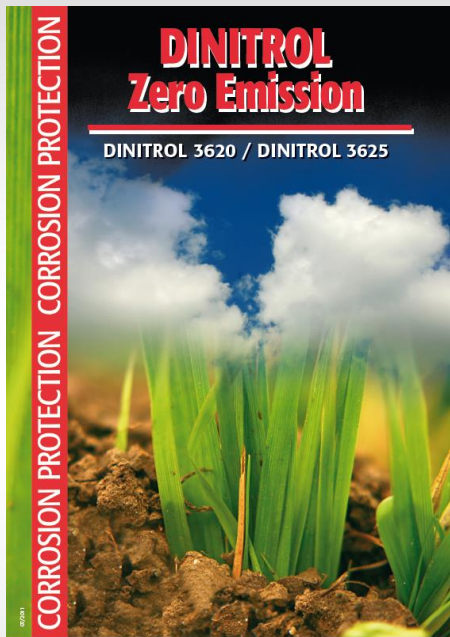

54% mindre løsemidler

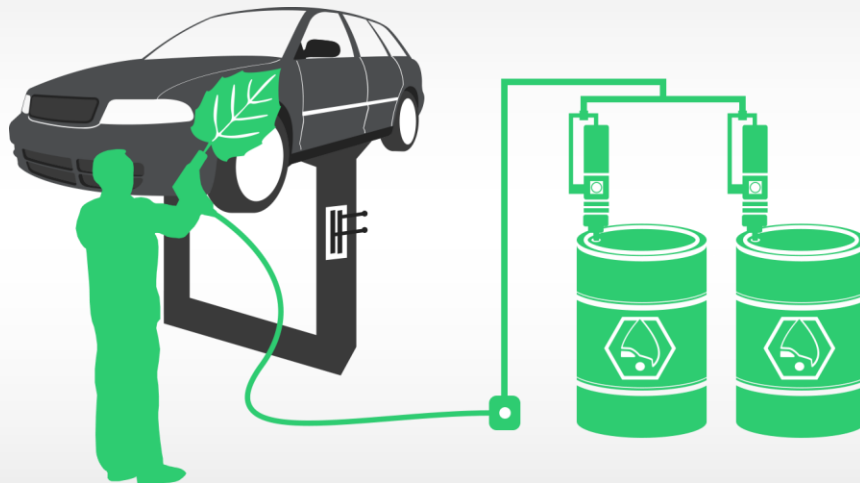

VERDENS BESTE RUSTBESKYTTELSE





	Technical Letter of Information
	Caution Vorsicht Varning
	SRS Airbag, Sensor etc.
	Plastic Plastik Plast
	Sound Installation Schall- & Impedanzmaterial Ljvånångerstrukturer

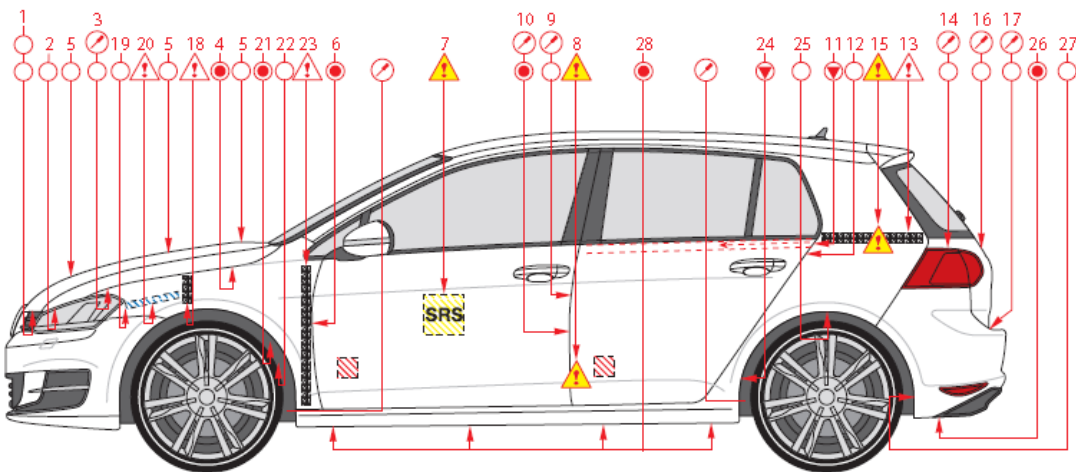

Vw Golf VII 2012-
2012 12 04

©Copyright. This is the property of DINOL GmbH
Pymontor Str. 76
D-32676 Lügde

VERDENS BESTE RUSTBESKYTTELSE



DINITROL® APPLICATION METHODS

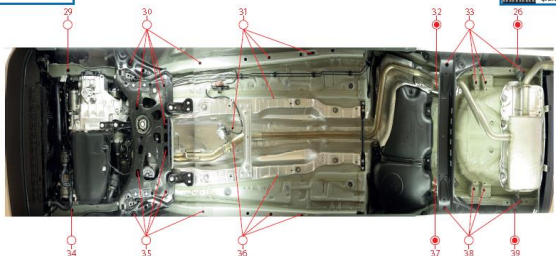

	Metallpartier Metallteile
	Galvan Zink spray
	Ud- skjult metal part
	Metall part skjult
	Indvendige overflader Gulvplader Gulvplader

Vw Golf VII 2012-
2012 12 04

©Copyright. This is the property of DINITROL GmbH
Pyrmonter Str. 76
D-32676 Logde

DINITROL® APPLICATION METHODS

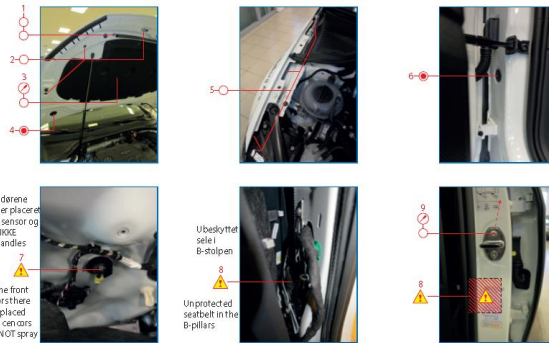

I fordrøene er der placeret SRS sensor og må ikke behandles

In the front doors there are placed SRS sensors do NOT spray

Ubeskyttet sele i B-støtten

Unprotected seatbelt on the B-pillars

Vw Golf VII 2012-
2012 12 04

©Copyright. This is the property of DINITROL GmbH
Pyrmonter Str. 76
D-32676 Logde

DINITROL® APPLICATION METHODS

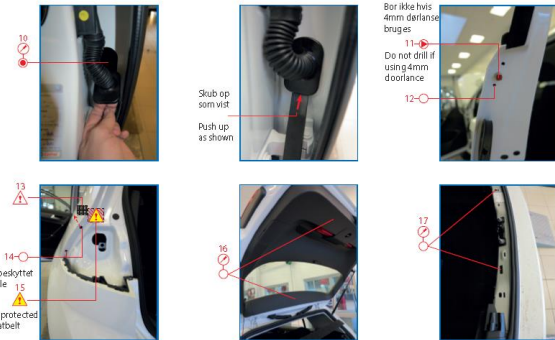

Bor ikke hvis 4mm der ikke bruges

Do not drill if using 4mm doorflange

Skub op som vist

Push up as shown

Vw Golf VII 2012-
2012 12 04

©Copyright. This is the property of DINITROL GmbH
Pyrmonter Str. 76
D-32676 Logde

DINITROL® APPLICATION METHODS

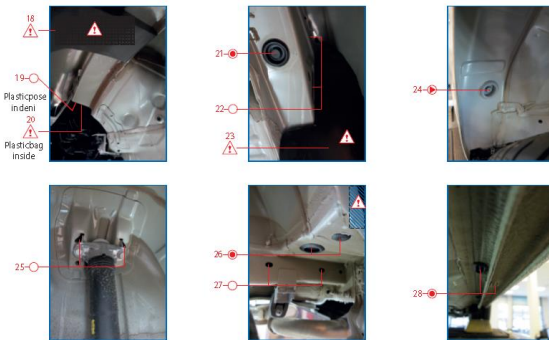

Plasticpose indeni

Plasticbag inside

Vw Golf VII 2012-
2012 12 04

©Copyright. This is the property of DINITROL GmbH
Pyrmonter Str. 76
D-32676 Logde

VERDENS BESTE RUSTBESKYTTELSE



Produksjon av sprøyteskjema CORROSAFE A/S



The diagrams are titled "DINITROL APPLICATION METHODS" and include the following content:

- Top Diagram (Car Side View):** Shows a side profile of a car with red spray lines indicating application points. A color-coded legend indicates different corrosion levels: Red (High), Yellow (Medium), Green (Low), and Blue (Very Low). The text "©Copyright 1993" is visible.
- Middle Diagram (Car Interior):** Shows the interior of a car with red spray lines. Text includes "©Copyright 1993" and "For the best spray pattern, hold the nozzle at a 45-degree angle." It also lists "Do not use if using arm distance" and "Do not use if using arm distance".
- Bottom Diagram (Car Interior):** Shows a car interior with red spray lines. Text includes "©Copyright 1993" and "Use Dinitrol on all plastic, steel, copper and aluminum". It also lists "Use on roof, door frames, inner fenders, floor plates, and battery" and "Do not use on painted surfaces".

VERDENS BESTE RUSTBESKYTTELSE





Vw Up 2 dr 2012-

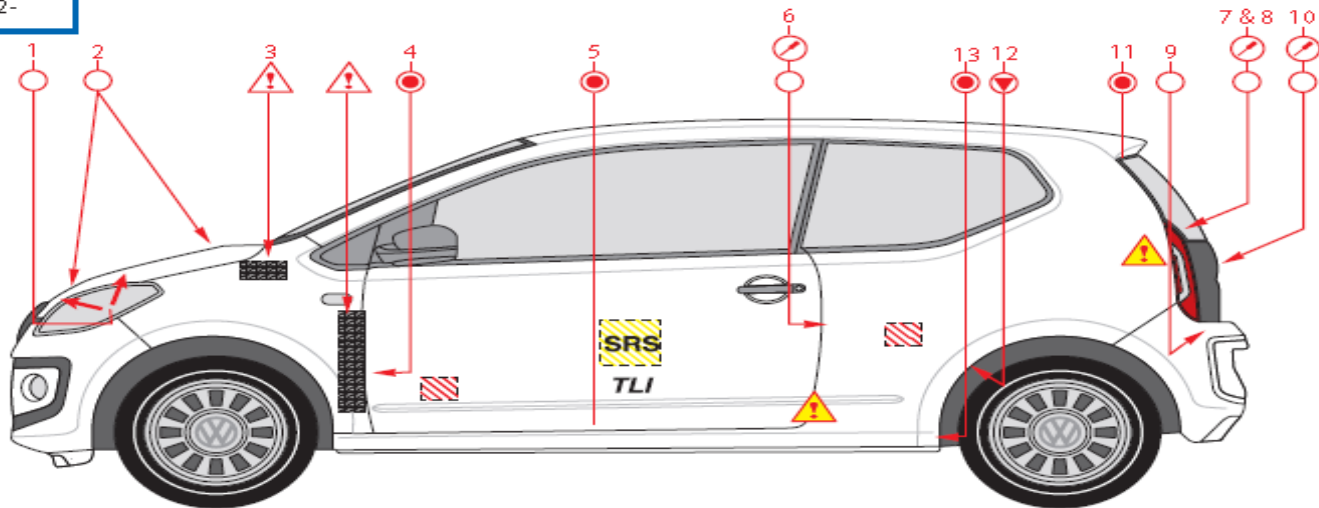

	Technical Letter of Information	
	Caution Vorsicht Varning	
	SRS Airbag, Sensor etc.	
	Plastic Plastik Plast	
	Sound insulation Schalldämpfendesmaterial Ljuddämpningsmaterial	

VERDENS BESTE RUSTBESKYTTELSE



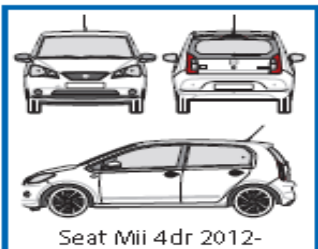

	Technical Letter of Information	
	Caution Vorsicht Varning	
	SRS Airbag, Sensoren etc.	
	Plastik Plastik Plastik	
	Sound Insulation Schalldämpfen des Motorraums Ljuddämpning av motorrum	

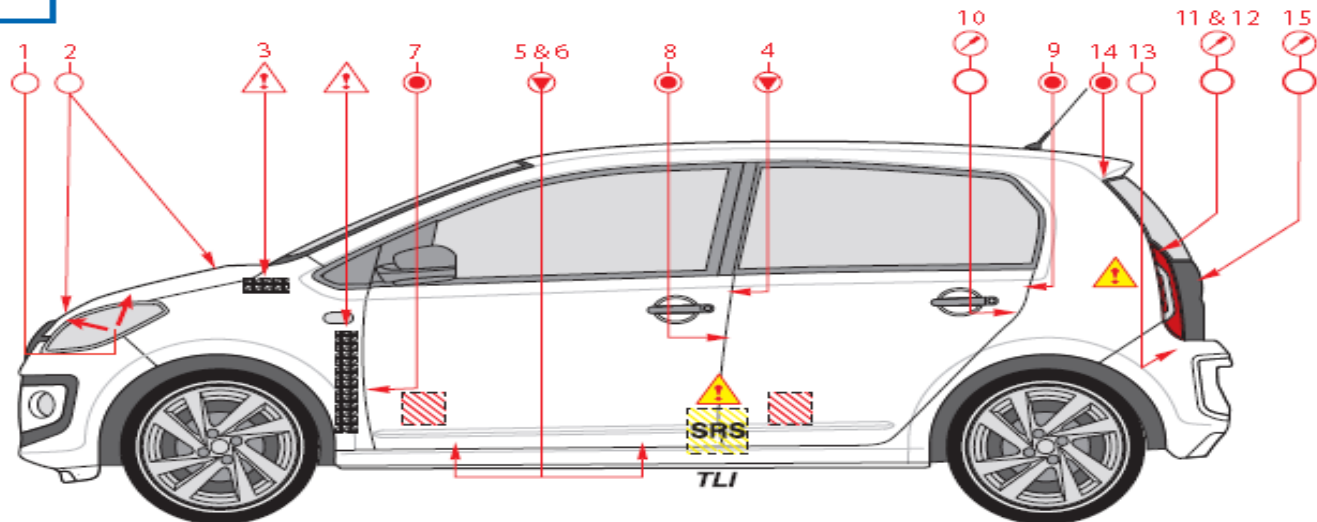

VERDENS BESTE RUSTBESKYTTELSE



SVAMP !!!



	Technical Letter of Information
	Caution Vindskit Varning
	SRS Airbag, Sensor etc.
	Plastik Plastik Plastik
	Sound Insulation Schalldämpfer des motorisierten Ljuddämpningsabstärkt

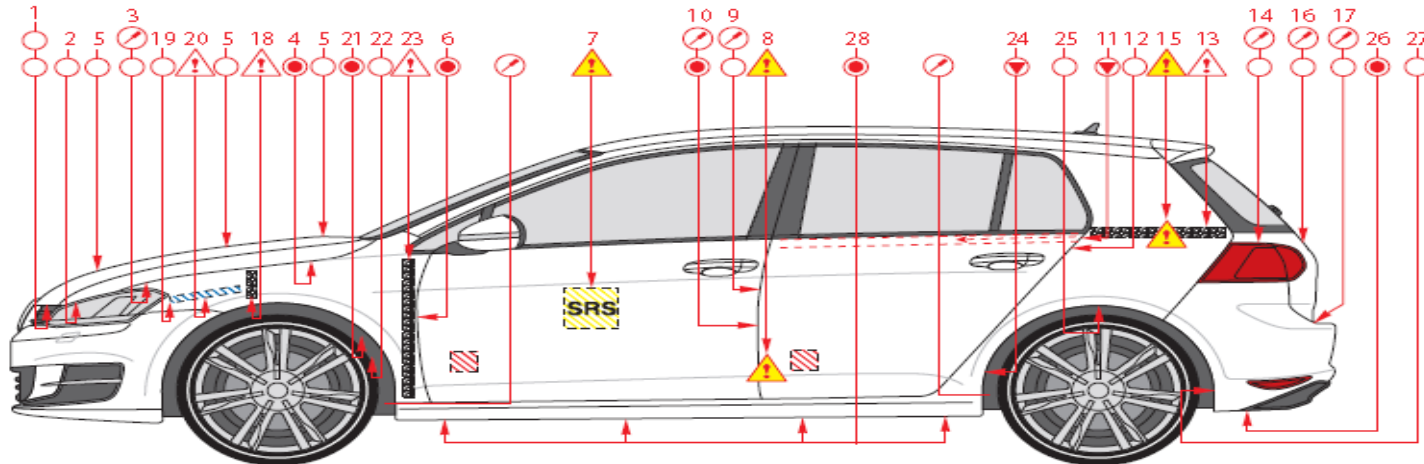

VERDENS BESTE RUSTBESKYTTELSE



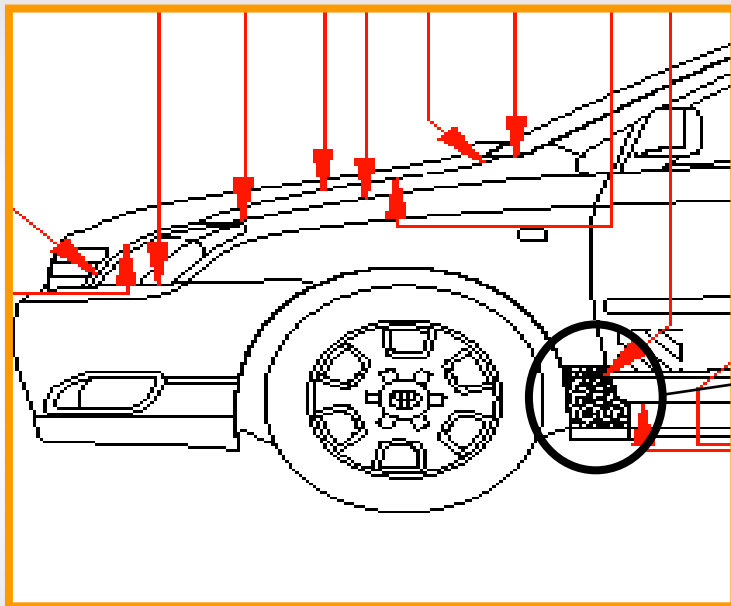

VERDENS BESTE RUSTBESKYTTELSE



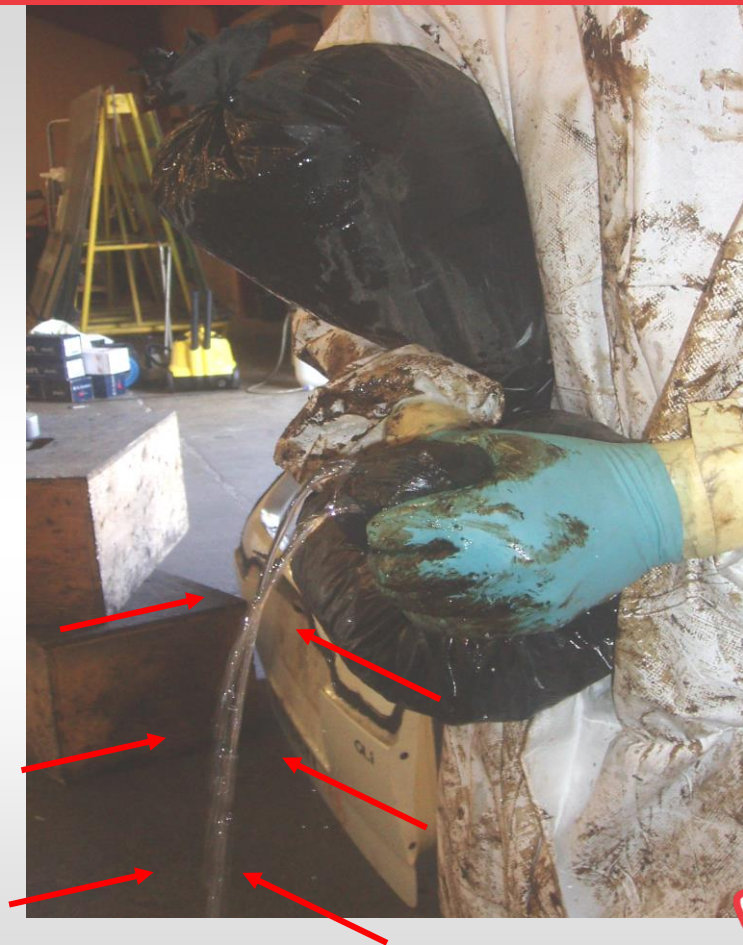

VERDENS BESTE RUSTBESKYTTELSE





VERDENS BESTE RUSTBESKYTTELSE



Strøken Bil sine praktiske lokaler



Europas fineste.
Miljømessig det
beste.

*renset, vaskning, oljevaskning og
tørring*



VERDENS BESTE RUSTBESKYTTELSE



Vognbunn NY bil i dag



Importbehandling
av åpne flater

VERDENS BESTE RUSTBESKYTTELSE



Beskyttelses deksler under NY bil i dag



Plastdeksler, filt deksler
brukes under bil.

Fuktige miljø.

Filtdeksler holder lenge på salt og fuktighet.
Bakside av filtdeksler under bil.



Demping av NY bil.
Eks. plastposer fylt med skum biter.



- Bakdelen holder på fuktighet ☹️

Vognbunn før og etter vask.



Saltskader må åpnes og tørkes
Før skaden mettes med kjemi



Fotodokumentasjon

VERDENS BESTE RUSTBESKYTTELSE



Dinitrols kundeportal på nett

www.dinitrol.no

BOOKING
24T

Dinitrol

Det beste vedlikehold!

Det blir korrosjon på alle biler, til og med din. Alle biler må vedlikeholdes. La ditt lokale Dinitrol Senter ta en gratis test av din bils beskyttelse.

Vedlikehold lønner seg!

For deg som bileier er det nesten umulig å oppdage om bilen er angrepet av "snikende" rust eller korrosjon. Vi vet hvor det kan være rust eller korrosjon på din bil.

Vedlikehold din bil nå!

Min side

Bruk din mobil eller email for å logge deg på.

Du kan og bruke koden du har mottatt på SMS eller fra senteret.

[Gå til Min side](#)

Ny kunde

Første gangen her?

Finn ditt Dinitrol Senter

[Søk](#)



Bilgedokumentasjon

VW Touran Vare
RJ76481

Klikk på sirkene

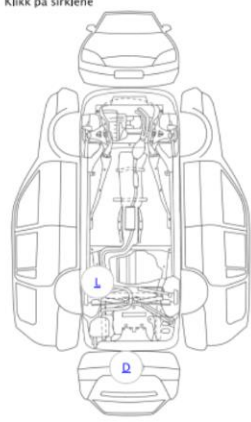

Møller Bil Sør Rogaland AS
Dinitrol Senter
4300 Sandnes
Rogaland

Telephone:
Email: molleberg@dinitrol.no

[Skriv ut](#)



Lakkrust



Bærearmer VB



Påbegynt rust vange over ex-potte

Rustkontroll
Tiltak : Spesial-behandling med oppfølging
inne 12 mnd.



VERDENS BESTE RUSTBEKYTTELSE

Sinkslipp



Typisk Sinkslipp

VERDENS BESTE RUSTBESKYTTELSE



Dealer portalen:

VERDENS BESTE RUSTBESKYTTELSE



System.dinitrol.no/dealer

Explain and Send Screenshots

Dinitrol

Logg



Hvorfor rustbeskyttelse?

Fuktighet i bilens hulrom året rundt.
Forurensing fremskynder rustprosessen.
Veisaltning fremskynder rustprosessen.

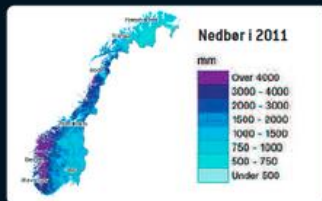

Biler er generelt ikke produsert for det harde og korrosive norske været.
Skiftende temperatur som danner fukt i hulrom og høy luftfuktighet året rundt.



Das Auto.

Møller Bil Åsane AS

Avdeling

Salg nybil

Navn

Mobilnr (Eier)

Registreringsnr.

Send SMS og Lagre



Vedlikeholdsbehandling:



Vedlikeholdsbehandling bør utbedres de nærmeste 3 mnd.

Tuff-Kote Dinol behandling Tilpasset vognbunn

- Dekkplater og innerskjærmer demonteres.
- Bil rengjøres med høytrykk, og tørkes.
- Prosedyre konsentrert om vognbunn med tynne vokspenetrerende produkter for hule profiler og vognbunn.
- Behandling avsluttes med slitelag på hele vognbunnen.
- Fotodokumentasjon på Dinitrol portal.
- Bil følges opp hvert 3 år.

Nødvendig tidsforbruk alle behandlinger 2 dager

Viktige detaljer:



VERDENS BESTE RUSTBESKYTTELSE



Explain and Send Screen Dinitrol



Das Auto.
Møller Bil Åsane AS

Avdeling

Salg nybil

Navn

Mobilnr (Eier)

Registreringsnr.

Send SMS og Lagre



Registrering

1. Kundens navn
2. Mobilnummer
3. Reg. nummer
4. Send SMS og lagre

1. Kunde blir tagget
2. Bonus grunnlag = fakturert behandlinger

Høyspent kabler EI / Hybrid biler



Ved understellsbehandling skal ikke høyspentkablene, ofte (oransje) sprøytes. Dekk til eller masker disse før behandling slik at disse fortsatt er godt synlige etter at bilen er ferdig behandlet.

Disse er ofte oransje eller en annen skarp farge for å indikere at det er høyspent!

Med vennlig hilsen

CORROSAFE AS
Dinitrol Norge

B
U
L
L
E
T
T
I
N
:

VW, Audi, Skoda og Seat.

Trykksensor Airbag i dører.

Problemstilling:

Bil produsenter er generelt skeptiske til sprøytetåke på / i trykksensor.

Arsak:

Membran er av ukjent materiale.

Tiltak:

Utvis særlig forsiktighet ved sprøyting innvendig i dører. Utvis særlig nøye lesning av sprøyteskemaer og TLI på nyere biler.

Se bilde nedenfor.



Sensor sett fra trykksiden.



Sensor sett fra underside

Teknisk leder

Jan Inge Håland

Dinitrol Norge

Bulletin:

CORROSAFE AS

Dinitrol Norge
Service Bulletin
[@corrosafe.no](mailto:post@corrosafe.no)



Service Bulletin: Info. Dato: 2012.10.15

VW Touran Type 2.

Grunnet siste vintres utvikling og eskalering av veisalting må vi utføre følgende kontroll.

På Modell som nevnt overfor skal følgende punkter kontrolleres:

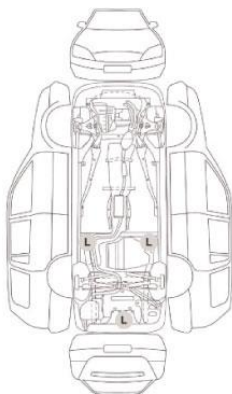

Plasserte
anmerkinger på
karosseri angir
kontroll punkt
på gjeldende
modell.

Corrosafe AS Tungen 14 4070 Randaberg post@corrosafe.no

Kontrollpunkt L & L:

Vange høyre og venstre side i overgang baksete brønn og varerom.

Kontrollpunkt L:

Overside drivstofftank og plate forlengelse av chassis på innside bakre støtfanger.

Definering av kategorier:

Kategori 1: Biler med slitt understells masse.
Typisk sinkutslag sveisepunkter.
Særtrekk: Ingen eller overflate har "kaffe søl" prikker.

Noe mer enn "kaffe søl". Kat. 1 +



Corrosafe AS Tungen 14 4070 Randaberg post@corrosafe.no

VERDENS BESTE RUSTBESKYTTELSE



Vedlikehold er en viktig investering

- ✓ Økt annenhåndsverdi
- ✓ Enklere driftskostnader
- ✓ Forlenget levetid
- ✓ Bedre passiv sikkerhet
- ✓ Lyddemping

Når skal bilen rustbeskyttes?

*Jo før, jo bedre
forebygge fremfor helbredelse!*



VERDENS BESTE RUSTBESKYTTELSE



Vedlikehold skal lønne seg!

Vedlikehold lønner seg!

Etter en vinter med bruk av veisalt er det viktig med vask og vedlikehold av kjøretøy.

Underspyling bør gjøres grundig etter hver sesong.

Kontakt din servicerrådgiver for råd om tilpasset underspyling.

For bestilling og booking se vår web-portal : www.dinitrol.no

Hvordan logge inn:

1. Skriv in mobil nummer
2. Passord mottas på SMS

Din Forhandler :

Rustbeskytt bilen din med
Dinitrol



VERDENS BESTE RUSTBESKYTTELSE

